

# Stress Analysis Solutions, Inc.

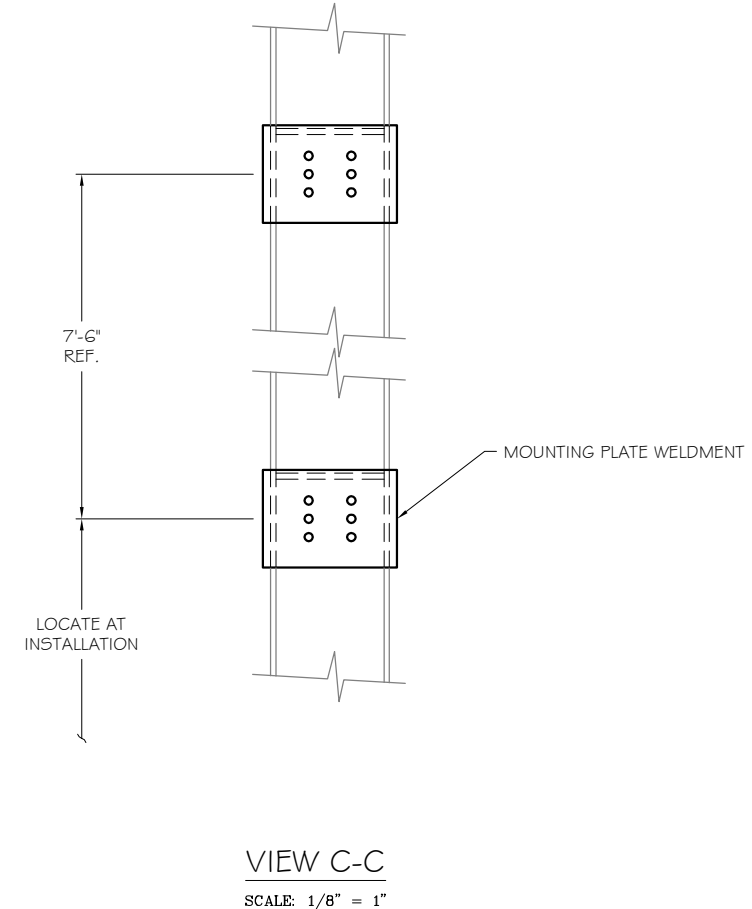
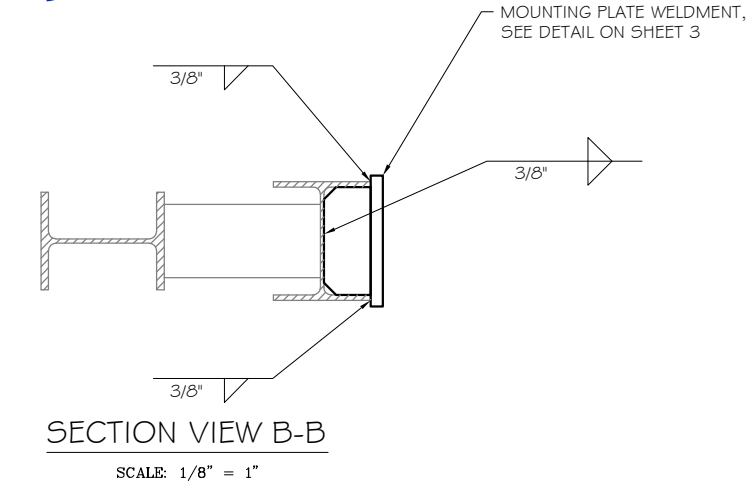
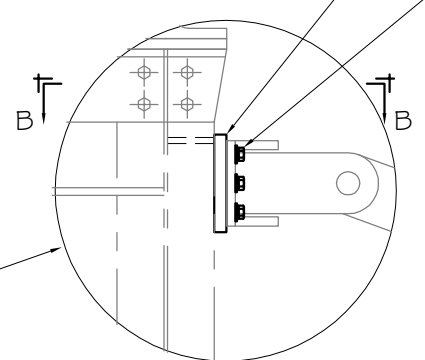
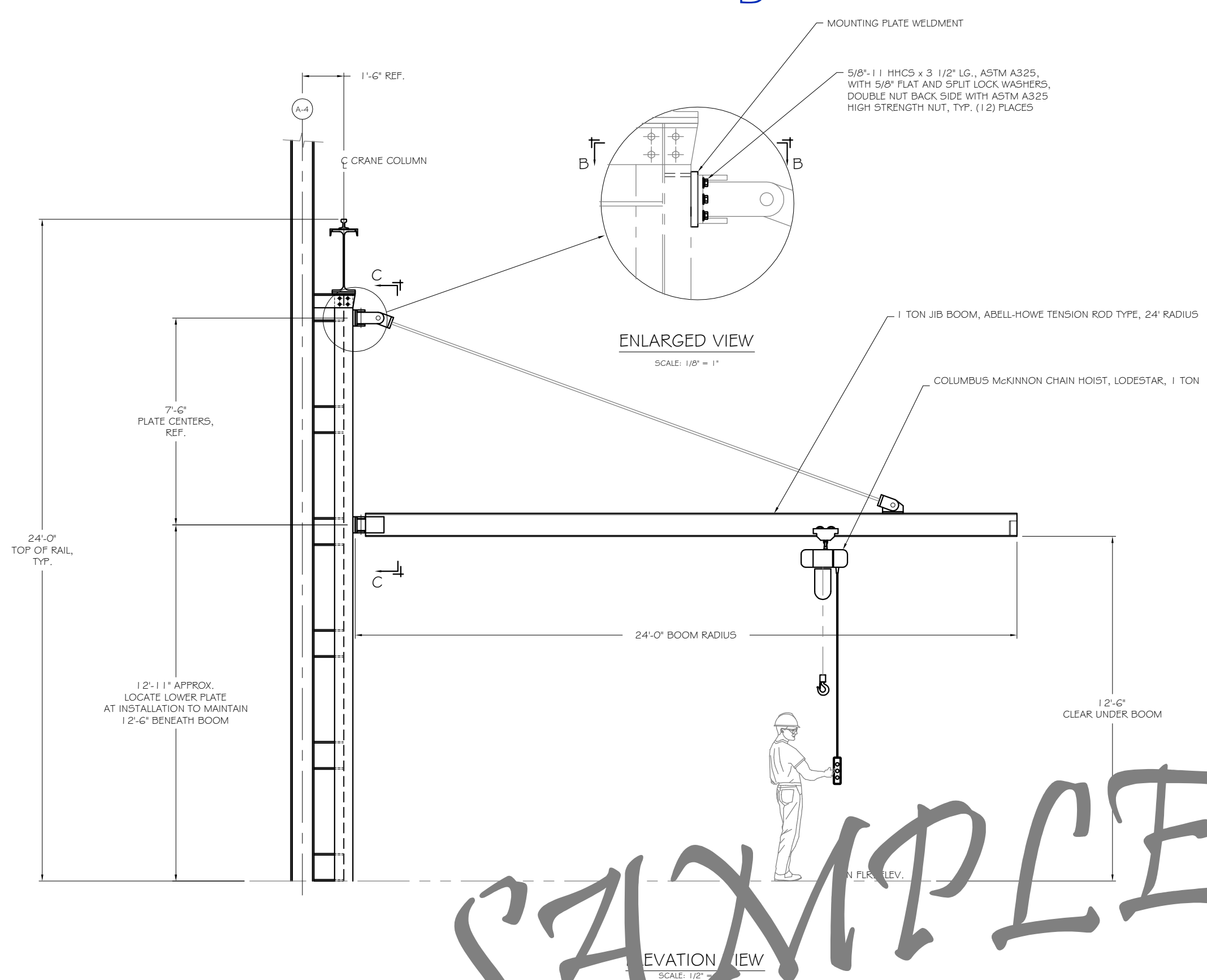

SAMPLE